

# D-TR DOOR™

*Prevents unauthorized entry into secure areas*

**A better alternative to traditional roll-up doors** - the new D-TR Door was designed and engineered to provide the security required in airport operations while minimizing the maintenance and repairs commonly associated with traditional roll-up conveyor doors.

**Other important design features include:**

- **Fewer moving parts**, resulting in reduced maintenance.
- **Simple design**-it's made from aluminum sheet and heavy-duty square tubing providing added strength and reduced weight.
- **Adaptable to any opening**-standard design is compatible with 39 inch or 46 inch and standard belt widths. Special sizes are available upon request.
- **Installation is fast and easy**, for new construction or the retrofit of existing installations.
- **Controls interface** - D-TR Door controls are wired directly into the conveyor controller. Under normal operation, conveyor will not start until conveyor controller has received a signal that the doors are open. Standard tape limit switches prevent closure on baggage left on the conveyor. D-TR Doors have internal limit switch control for maximum opening and closing travel.
- **Fast delivery** - most D-TR Doors are in stock. Standard shipment lead time is one week. Large quantities or custom sizes may require a longer lead time. All units are prewired and factory tested.



Dimensions shown are  
for a 39" conveyor

# D-TR DOOR™

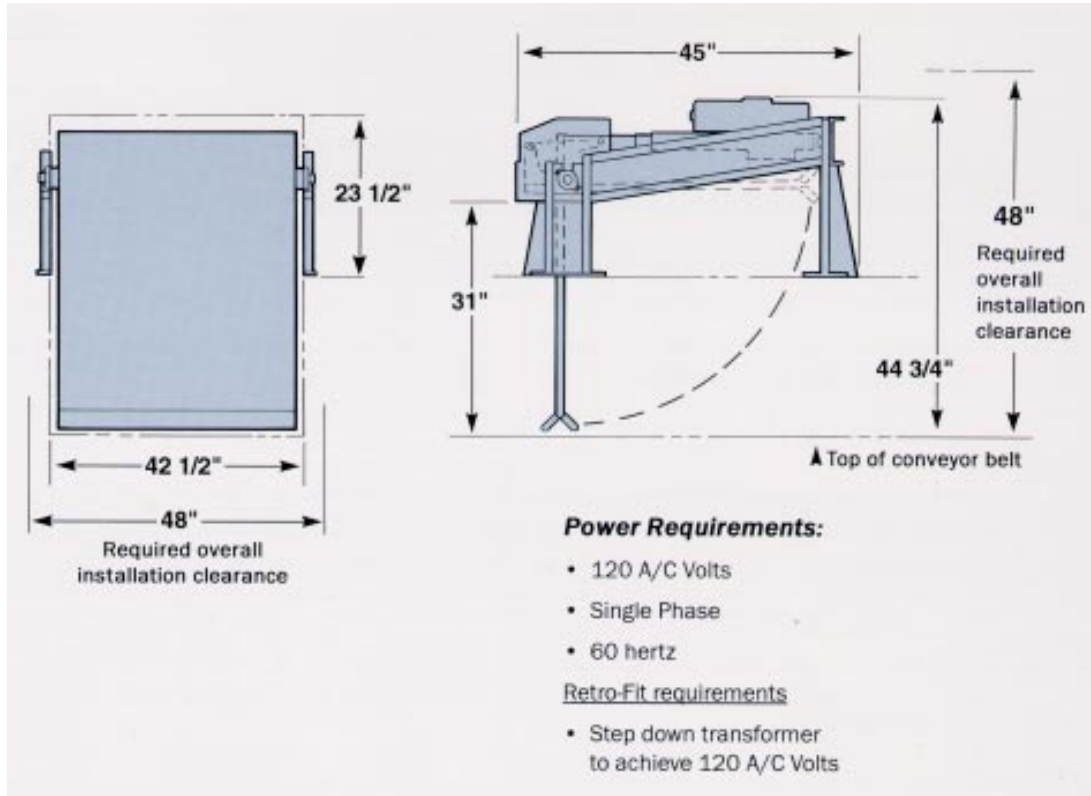

D-TR DOOR™ is a trademark of the Jervis B. Webb Company

Webb airport services offers preventative maintenance, control support, and 24-hour emergency repair for any type of baggage handling conveyor equipment, or non-conveyor equipment including:

- passenger bridges
- guide-in lighting systems
- preconditioned air equipment
- potable water cabinets
- ground support equipment
- general building services

For information call:

**Jervis B. Webb Company Airport Services**  
3770 Zip Industrial Blvd., Suite B, Atlanta GA 30354 USA  
1-800-752-9322 FAX: 1-404-768-9710  
(1-800-7JB-WEBB)

**Jervis B. Webb Company**  
MATERIAL HANDLING SYSTEM SPECIALISTS



Bulletin No. 9151  
©1994 Jervis B. Webb Company