

SmartLoader® AGV Automates Shipping and Receiving Operations for Anheuser-Busch, Inc.

SmartLoaders effortlessly load trailers on all three shifts at the Baldwinsville, New York plant.

Since 1919, the Jervis B. Webb Company has been a world leader in providing innovative material handling solutions that increase productivity, improve product quality and provide production flexibility. As a pioneer in the development of Automatic Guided Vehicles (AGVs), Webb offers some of the industry's most advanced solutions. From wire guidance to inertial guidance and now "trailer guidance" technology, Webb has a long history of successful AGV installations in a variety of challenging industrial and commercial environments. So when Anheuser-Busch, Inc. sought a way to automate its warehousing operations, it turned to the Jervis B. Webb Company.

Anheuser-Busch's Baldwinsville, NY brewery was running a three-shift operation five to seven days a week. Anheuser-Busch approached Webb about providing a system that would automate its trailer loading operations. Anheuser-Busch desired an innovative way to move product 24/7 within the warehouse, while maintaining trailer load time and accommodating peak loading periods.



Building upon its intelligent AGV technology, Webb engineers designed the SmartLoader AGV to move loads into conventional trailers without guidance wires, lasers or magnets. The SmartLoader uses technology adapted from Webb's proven inertial guidance systems to reliably deliver palletized loads in multiple configurations into any standard over-the-road trailer.

Webb's new SmartLoader system can move loads from palletizer output, warehouse, rack or floor staging into conventional over-the-road trailers without manual intervention. No modifications to the trailer are necessary because

the vehicle guidance system adapts to the length and skew of each trailer. Once inside, the vehicle fills the trailer based upon Anheuser-Busch's loading configuration requirements.

Two different guidance systems maximize the loading capabilities of SmartLoader. Developed by Webb engineers, the proprietary trailer loading guidance system utilizes sensors to guide the vehicle through in-trailer loading operations. When maneuvering around the warehouse, SmartLoader relies on an inertial guidance system and an on-board Vehicle Control Computer (VCC-3) to accurately main-

tain the intended path and perform required tasks. SmartMark® transponder devices embedded in the floor along the guide path are sensed by the AGV to identify its exact location.

A Vehicle System Manager (VSM™) is also used to provide a proven means for real-time control and monitoring of all vehicles within the system. Through the VSM, the SmartLoader vehicle is capable of picking loads from any programmed point in the warehouse and either moving them to a

new location or loading them into a trailer. Load configuration can either be pre-programmed into the AGV or broadcast to the vehicle via the VSM on a real-time basis. The load configurations can include single loads from pairs, consolidating single loads into pairs, as well as patterning load configurations to maximize trailer staging area, and dock floor space utilization.

Webb's SmartLoader AGV provides a balanced solution to meet the needs of Anheuser-Busch. Use of the vehicle minimizes human expo-

sure to potentially harmful spills and reduces accidents and ergonomic injuries, while adding an additional level of protection for the product. Additionally, the vehicle works around the clock with no downtime. And because it runs on battery power, the vehicle automatically enters into a power save mode after extended idle periods - saving the company unwanted energy costs.

Anheuser-Busch has 36 SmartLoader AGVs currently in use, and has plans to automate several more facilities.

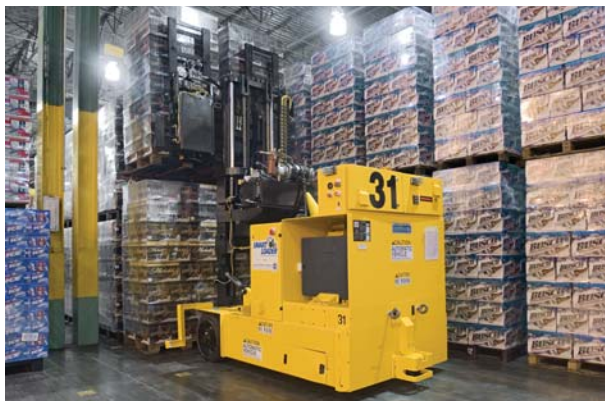

A SmartLoader picks up a load from floor storage



SmartLoaders can load trailers in virtually any load pattern

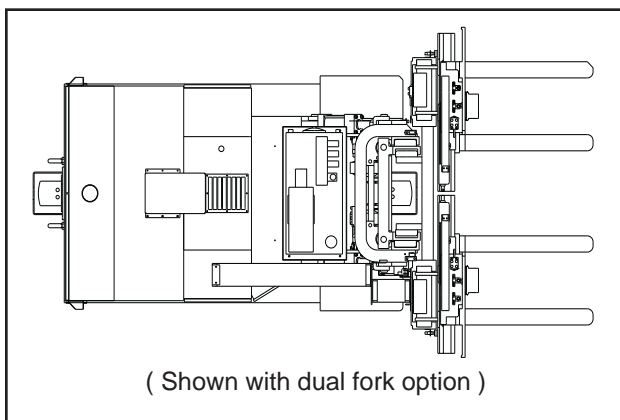

ATL-AGV Specifications

| | |
|---|-------------------------|
| Capacity, Gross Load | 4,800 lb |
| Vehicle Speeds (automatic) | 20 to 300 FPM |
| Stopping Accuracy (vehicle fleet) | +/- .5 in |
| Maximum Fork Height | 114 in |
| Maximum Fork Height (stacker option)..... | 18 ft |
| Ground Clearance | 4 in |
| Battery | Sealed Maintenance Free |
| Battery Voltage | 48 VDC |
| Battery Capacity | 570 AH |
| Vehicle Weight w/battery | 12,668 lb |