

S P E E D

S P E E D

BAGGAGE CONVEYOR

EFFICIENT

The belt conveyor is one of the most versatile and simplest material handling machines available today. It provides an economical and practical means of transporting baggage over long distances. The patented Webb High Speed Belt conveyor is designed specifically for demanding BAGGAGE HANDLING applications.

FAST

Standard design methods commonly available are used for distances of up to 250 meters, moving baggage at speeds up to 5.2 meters per second. We've taken this basic design to the next level by creating a high speed belt conveyor capable of spanning distances of 600 meters or greater, conveying baggage at speeds over 10 meters per second.

RELIABLE

The continuous belt surface helps to eliminate baggage hang up on the conveyors. In addition, this new generation of conveyors interface smoothly with automatic identification and baggage screening equipment. The Webb High Speed Belt conveyor can reliably transport baggage from 2 to 55 kg. in weight, at faster throughput and with greater accuracy.



At left, this side-by-side design prototype unit operates at a speed of 10.7 meters per second, with a 40 bag per minute throughput rate.

Below, an over and under design offers high speed performance. This conveyor is currently operating at a major U.S. airport facility doubling previous baggage throughput capacity.



EASILY MAINTAINED

This system is designed with fewer moving parts that have longer operating life than conventional baggage conveyors, improving system reliability and maintainability. With fewer components, less maintenance is required to keep the system at peak performance, and less maintenance equates to lower "whole life" cost of the equipment.

HIGH SPEED

BAGGAGE CONVEYOR

Two design options are available:

- **Side-by-Side** (right)
- **Over and Under** (below)

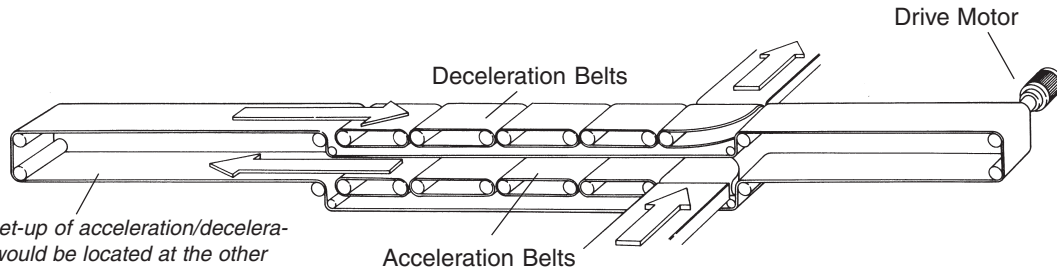
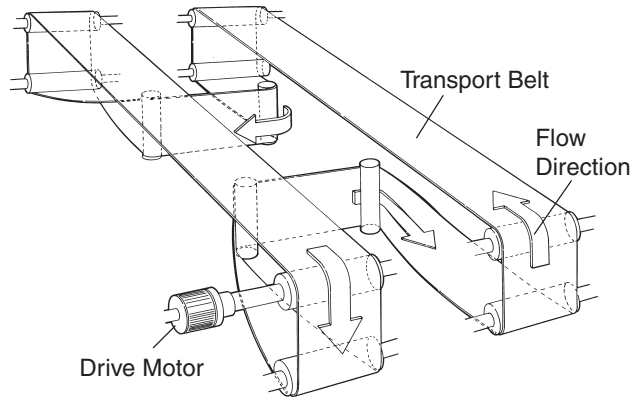

A similar set-up of acceleration/deceleration belts would be located at the other end of the transport belt.

Acceleration / Deceleration Modules, equipped with variable frequency drives, are utilized in a series of independent conveyors to facilitate a controlled, progressive increase/decrease in velocity of baggage as it approaches or discharges from the transport belt. Baggage is received from and discharged to low-speed conveyors at a speed of 1.8 meters/second.

The system is designed to handle baggage sizes as follows:

Normal

Items that can be processed by the equipment without special handling must fall within the physical characteristics profile shown in the chart below to be considered Normal Baggage.

	Maximum	Minimum
Length	900 mm	300 mm
Width	500 mm	100 mm
Height	750 mm	200 mm
Weight	55 kg	2 kg

Items outside the physical characteristics profile fall into two categories:

Fragile/Odd sizes

Items such as garment bags, hat boxes, bowling balls, shopping bags, etc., when in tote trays can be processed as normal baggage.

Oversize

Items such as animal cages, map cases, golf bags, duffel bags, etc. cannot be handled by the equipment and must be manually transported.

JERVIS B. WEBB COMPANY
WORLDWIDE MATERIAL HANDLING SOLUTIONS



34375 West Twelve Mile Rd., Farmington Hills, MI 48331-5624 USA
1-248-553-1220 Fax: 1-248-553-1228
E-mail: info@jerviswebb.com www.jerviswebb.com